

Rollbag R3200 Bagger Specifications

Speed	up to 80 bags/min
Bag width	2" – 16"
Bag length	3" – 32"
Bag thickness	1–5 mil
Seal bar opening	6"
Electrical	120V @ 15A
Air	80psi @ 5CFM
Warranty	1 year, extendable up to 5 years
Dimensions (W x D x H)	34" x 44" x 38" – 44"



Operating Options

The Rollbag R3200 has a variety of machine operating options to maximize user efficiency.



Footswitch—Bagger cycle is operate with a footswitch, allowing the operator to have both hands free during filling of the bag.



Hand Activation Sensor—This sensor detects the presence of the operator's hand above the loading area. Once the operator drops in the product and removes their hand from the loading area then the machine automatically cycles. This sensor eliminates a step in the packaging process, as the operator does not need to press a button or foot switch to cycle the bagger.



Product Detection Sensor—When the product detection sensor detects the product in the bag, the seal bar closes and seals the bag. The sensor is mounted underneath the seal bar and can be moved along the load shelf.

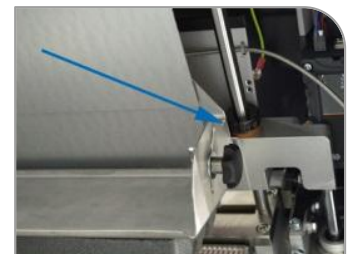

Adjustable Seal Bar Opening—This option reduces the stroke of the seal bar to be slightly greater than the bag opening which increases the packaging speed. Ideal when using small bags.



Articulating Bag Support—This option supports the bag during the sealing process. At the end of the cycle the load shelf tilts down at an angle, dispensing the bag to the next step of the packaging operation. The maximum bag length with the standard articulating bag support is 18".



End of Roll Sensor—This sensor detects when the roll of bags is nearly empty and stops the bagger in order to allow changeover to a new roll of film.



Elevated Machine Frame—The elevated machine frame is designed for those that have bags longer than 24" and want to put a conveyor underneath it. This option is also used for tall operators that want to pack products while standing, as the loading height would be great than 36".

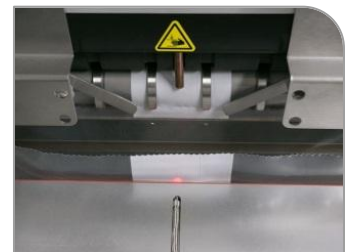

Bag Open Sensor—The Bag Open Sensor assures that when a bag is in the load position it is open and ready to accept product

Rollbag™ R3200 Automatic Bagger

High Speed, Versatile, Reliable Packaging

The Rollbag™ R3200 automatic bagger is the ultimate automatic poly bagger for high speed, versatile, and reliable packaging.

The R3200 automatic bagger can cycle at speeds of up to 80 bags per minute using Rollbag pre-opened bags on a roll. With the optional bag maker assembly this bagger works with poly tubing, making the bag to the desired length while reducing material costs. With the ability to run bags as small as 2" x 3" to as large as 16" x 32", this bagger offers extreme flexibility

The Rollbag R3200 bagger features a compact design and is assembled with high quality off-the-shelf components. This sleek automatic bagger is designed to withstand rigorous manufacturing environments and maximize uptime.

The Rollbag R3200 can be equipped with a range of options, printers, and feeding devices, to maximize your packaging process.

The Rollbag R3200 features a 1 year limited warranty which can be extended up to 5 years with our optional comprehensive warranty.



Operating Benefits

- 7" color touchscreen with user-friendly interface and clear prompts
- PLC with job storage, batch counters, packaging statistics, and login-in levels
- Built in self-help diagnostics for troubleshooting
- Compact design takes up minimal footprint in the packaging area
- Standard operating height of 34.5" (adjustable from 30.5" to 36.5")

Set-Up Benefits

- Utilizes Rollbag pre-opened bags on a roll for quick bag size changes and easy set-up
- Use with poly tubing (optional), for lower material costs and ability to change bag length on the fly
- Interface ports to integrate counters, scales, and robotics
- Adjustable height load shelf to support the bag (up to 18" length) during packaging
- Ceramic heating element for fast start-up



Easy load bag opener squares open and grips the bag

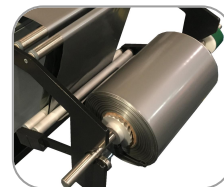

Poly tubing greatly reduces material and shipping costs

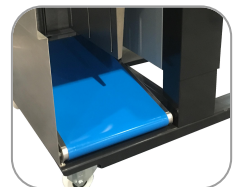

Integrated outfeed conveyor is height and angle adjustable

Maintenance Benefits

- Self-diagnostics ensure quick problem solving
- Quick service access to all pneumatic and electrical components
- Remote networking capability for improved troubleshooting
- Off the shelf modular components for easy replacement
- Comprehensive 5-year warranty (optional) which includes consumable parts & labor

Safety Benefits

- Low pressure seal bar closing
- Low power consumption design (1100 Watts)
- Safety cover protects access to the seal bar (when using a funnel)
- CE compliant design for improved safety and troubleshooting



a PAC Machinery company

Material Options

The material options work to optimize appearance or remove excess air from the finished package.

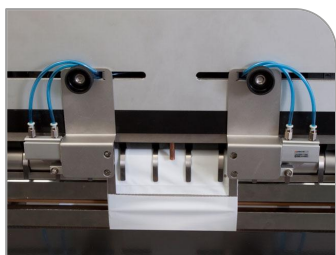

Seal Flattener Fingers—Seal Flatteners work to hold bag taut during sealing to minimize wrinkles. Also shown is the bag in open position before bag is stretched for sealing.



Air Expeller—The air expeller is a plate with a foam pad. This device presses against the bag prior to sealing, removing excess air.



Static Eliminator—This option removes static electricity that could be in the bags. The eliminator neutralizes the static charge and is especially beneficial with thin bags.



Adjustable Hole Punch—Pneumatic punch that puts a small perforated hole (flutter vent) in the bag, allowing for excess air to escape.



Film Perforator—The film perforator has an upper and lower assembly which creates a vertical perforation along the complete length of the bag. This perforation allows air to vent out of the bag after it has been sealed.



Film Guides—The film guides assure that the packaging material goes straight into the bagger by keeping the film in a fixed position. This option is ideal for narrow bags and poly tubing.

Poly Tubing Options

Make bags of the desired length with the Bag Maker Assembly plus more tubing options to customize your package!



Bag Maker Assembly—The bag maker assembly allows the R3200 bagger to use poly tubing, in addition to pre-opened bags on a roll. With poly tubing the user can change the desired bag length at the push of a button, since the bag is made on demand. The assembly applies a bottom seal to the tubing, as well as perforates and opens the material, prior to loading. When using poly tubing the R3200 will run up to 40 bags/min (dependent on bag size, gauge, and product).



Seal Bar with Hang Hole—A seal bar that also creates a hang hole near the top of the bag to allow a package to be placed on a retail display hook.



Chain Bags—More than one bag or compartment can be made out of the Poly Tubing before being separated. A strip of bags can be made.

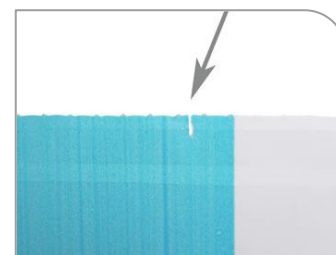

Tear Notch—This option creates a tear notch which allows a bag to be easily opened by the customer.

Printing Options

It is possible to mount all kinds of printers and label applicators on the Rollbag R3200

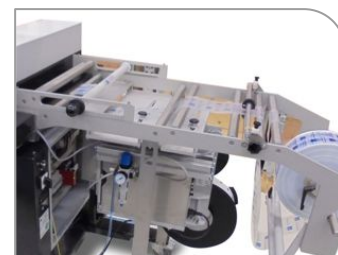
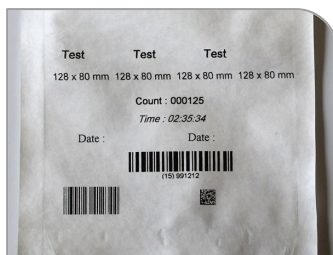

Thermal Transfer Printer—If you need to print large text, images, or barcodes on your bag, then a thermal transfer printer is the right solution. Our Videojet thermal transfer printers are available in various widths, to accommodate different printing requirements. Additionally, printing software is available in order to make print set-up a breeze.

Inkjet Printer—If you need to print small text, date, time, or logos on your bag then an inkjet printer is the way to go. This compact inkjet printer allows you to print information that is up to 1/2" high by up to 36" in length

Label Printer Applicator—Integrated label printer applicator ties into warehouse management system to print and apply a label directly on the outside of the bag.

Product Loading Options

Product loading options are available to meet a variety of packaging requirements.

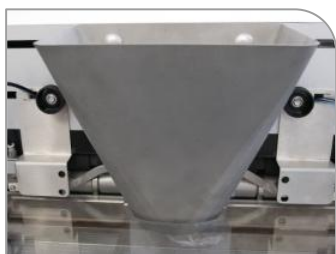

Fixed Funnel—The funnel guides the product into the bag. The funnel is mounted above the seal bars and can be used for manual or automatic filling. It is made of stainless steel and comes in a range of sizes.

Accumulating Funnel—The stainless steel accumulating funnel is designed to accumulate parts prior to being dropped into the bag. This type of funnel is optimal when a feeder is used. The accumulating funnel allows the feeder to keep feeding parts while the bagger cycles. It also ensures that multiple parts get dropped into the bag at one time, as the funnel only opens when the bag is in position

Easy Load Bag Opener—Several features in one! First, this system creates a square or rectangular opening for ease of loading product into the bag. Second, the system physically grips the bag to support heavier products in the bag. Last, the easy load bag opener includes seal flattener fingers, which stretch the bag tight prior to sealing, minimizing wrinkles in the seal area.



Bag Holder—The bag holder is useful for getting a straight seal when packing free-flowing bulk products. It can also be used as an anti-stick device to prevent light bags from sticking to the sealing bar.

Sorting Table—A prep area placed on top of the machine, allowing the operator to prepare the products that will be packaged.

Sorting Table with Frame—A prep area that is placed over the top of the machine. This provides a space for the operator to prepare the products that will be packaged.

Feeding Options

The Rollbag R3200 works with a wide variety of infeed devices for the optimum in efficient packaging.

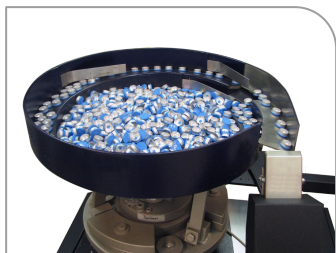

Bowl Feeder Counter—A vibratory bowl feeder can be integrated with the Rollbag R3200. The bowl feeder can automatically feed products one-by-one in a single direction into the packaging area of the Rollbag R3200.



Vision Counter—The Vision Automatic Counter option can be integrated with the R3200 to create an extremely accurate automatic bulk counting and bagging system for packaging small parts.



Kit Counting Conveyor—A special tray table and conveyor with moving compartments to feed items into the machine. This conveyor will increase efficient packaging of single items and "kits" which are groups of items together.



Weigh Counter—For an efficient and accurate count of a high volume of identical parts a weigh counter can be integrated with the Rollbag R3200.

Outfeed Options

Streamline the packaging process with an outfeed option.



Robotic Feeding—The funnel guides the product into the bag. The funnel is mounted above the seal bars and can be used for manual or automatic filling. It is made of stainless steel and comes in a range of sizes.



Interface Port with Cable—The funnel guides the product into the bag. The funnel is mounted above the seal bars and can be used for manual or automatic filling. It is made of stainless steel and comes in a range of sizes.



Bag Support Outfeed Conveyor—Instead of a load shelf to support the bag, it is possible to use a bag support outfeed conveyor. This conveyor supports and lifts the bags during sealing, then the sealed bags are transported to the left or right side of the bagger. This conveyor allows the operator to comfortably stand or sit in front of the bagger during packaging.



Outfeed Conveyor—The outfeed conveyor transports bags from the bagger up to table height. With every cycle of the bagger, the conveyor indexes one step. The outfeed conveyor is available in 10" and 16" widths. Use in front of the bagger, like in the picture, or to the side of the machine.

Safety Options

Options are offered for additional operator safety.



Dual Touch Start Switch—Two switches that must be touched simultaneously in order for the machine to cycle. This ensures hands and fingers are not in the seal area while the machine is cycling.



Light Curtain—Prevents the operation of the bagger when the optical detection field is obstructed. Can also be used to trigger the start of the cycle, once the obstruction is no longer detected.



Safety Circuit—Allows for the safety system of the bagger to be integrated to an external safety system, which would be the master of the circuit. Reset of the circuit can only be done after the master has been reset.

Maintenance Options

We understand that packaging equipment is critical to your operation, we provide maintenance options for maximum up-time.



Light Warning Tower—Visual indicator of the current operating status of the bagger, red for a system stop, yellow caution, and green for normal machine operation.



220V Operation—With this option, the bagger will work with 220V single-phase electricity. Designed for packaging locations that do not have 120V available, or those that want to use a lower amperage circuit in conjunction with 220V.



Spare Parts Kit—This kit includes basic consumable and replacement parts for the machine. These parts include PTFE seal bar cover, pressure rubber, and perforation knife.



Touchscreen Cover—A clear plastic cover that protects the touchscreen from dirt, dust, and damage

Custom Engineering

Because no packaging lines are the same, the Rollbag R3200 can be tailored for optimal operation in any packaging environment. Here are a few of our customized automatic baggers, built to order.



Conveyor Belt
Thermal Transfer Printer
Stop Light for alarm indication
Level sensor
Funnel with counter
Bag stretcher
Heavy product clamps
Bag open detection



Special Arm for Control Panel
Accumulating funnel with Window Sensor
Power switch lockout
Heavy product clamps
Handshake



Extra Wide Funnel
Heavy product clamps and bag stretcher
Bag support table + lift
Bag on a roll sensor
End of film sensor
Handshake
Print Signal



Sorting Table with Frame
Chain bag (2x)
Bag stretcher
Accumulating funnel
Film Perforator
Footswitch

More versions of the Rollbag R3200

These Rollbag packaging systems are designed with specific packaging applications in mind.



Rollbag R3200 Fulfillment Bagger with Scanner
A compact, modern, and robust design for bagging products automatically in poly mailers.



Rollbag R3200 with Vision Counting System
This bagger is an extremely accurate automatic bulk counting and bagging system for packaging small parts.



Rollbag R3200 Medical with Printer
This medical pouch sealer is capable of being independently validated and is designed for clean room use using Tyvek® Poly or medical-grade paper rollstock.

Warranty, Service and Support

PAC Machinery has created three warranty levels to provide coverage to match your machine usage. Combine this with the recommended start-up training available in your facility to get the maximum benefits. See your proposal for more details.

1
Year

Standard 1-year is limited to repair of the machine and replacement of defective parts.

3
Year

A comprehensive 3-year warranty including Replacement Parts, Consumable Parts, Bagger Warranty Repairs, Start-Up and Training, Art & Plates discount, Material Price Protection, and requires the exclusive use of Rollbag brand material.

5
Year

A comprehensive 5-year warranty including Replacement Parts, Consumable Parts, Bagger Warranty Repairs, Start-Up and Training, Art & Plates discount, Material Price Protection, and requires the exclusive use of Rollbag brand material.

For a complete packaging solution use Rollbag brand pre-opened bags on a roll and Rollbag tubing

For maximum packaging uptime use Rollbag brand pre-opened bags and Rollbag poly tubing, Rollbag brand products are the perfect compliment to Rollbag Systems automatic packaging equipment and, if used exclusively, Rollbag Brand products can extend your Rollbag machine warranty.



Custom Rollbags & Poly Tubing

Bags can be custom manufactured with a variety of different features, tailoring them to your specific requirements. Custom printing is available from simple one color printing to complex multi-color printing. CT manufactures bags and tubing from a variety of materials, the most popular is Linear Low Density Polyethylene (LLDPE), chosen for it's high strength and clarity.

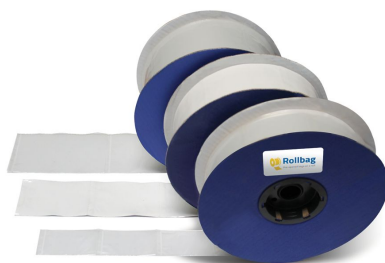

Stock Rollbags

Stock Rollbags are pre-opened bags on a roll that typically ship within two business days. Stock bags are manufactured in a variety of sizes and thicknesses, in both clear and duplex (white front / clear back) material.

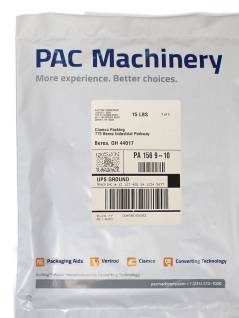

Coex Poly Mailer Rollbags

Coextruded Poly Mailers are available in pre-opened bags on a roll or tubing, designed for mail order fulfillment.



High performance thermal transfer ribbons are designed specifically for printing on flexible packaging.

Dimensions

The R3200 Automatic Bagger features a compact design that takes up minimal footprint in the packaging area.

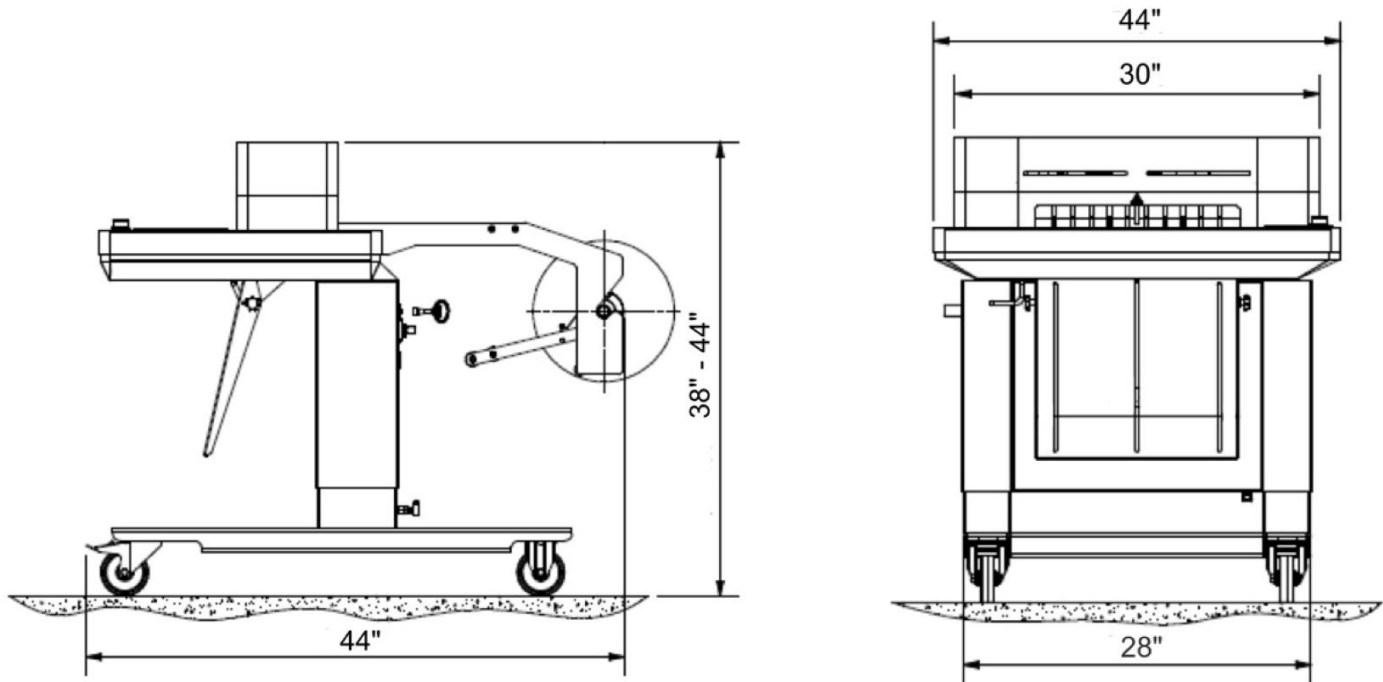

Rollbag™ Systems automatic baggers deliver exceptional value, speed and flexibility for automatic bagging operations. The Rollbag series of machines uses pre-opened bags on a roll and a revolutionary compact form/fill/seal system that utilizes tubing in addition to pre-opened bags on a roll. The tubing system offers a low resistance design that provides the benefit of lower material costs as it forms bags in-line before they are filled and sealed.

We invite you to contact our packaging experts at PAC Machinery for your complete packaging solution.

Contact us today:

1 (234) 222-1000 ■ sales@pacmachinery.com



Rollbag Systems

a PAC Machinery company

775 Berea Industrial Parkway, Berea OH 44017 ■ (234) 222-1000 ■ pacmachinery.com

Specifications subject to change without notice